

HOME AUTOMATION USING ARDUINO

Mr. GIRIPRASAD¹, SHIVARANJANI.M.S², SAKTHISOWMIYA.R³, PRIYA.P⁴, MENAKA.V⁵.

(AssistantProfessor¹, Student², Student³, Student⁴, Student⁵)

Department of electronics and communication.

COIMBATORE INSTITUTE OF ENGINEERING AND TECHNOLOGY.

Coimbatore-641109.

Abstract— This paper provides a low cost-effective and flexible home control and monitoring system with the aid of an integrated micro-web server with internet protocol (IP) connectivity for access and to control of equipment and devices remotely using Android-based smartphone app. The proposed system does not require a dedicated server PC with respect to similar systems and offers a new communication protocol for monitoring and controlling the home environment with more than just switching functionality. Smart home interfaces and device definitions to ensure interoperability between Wi -fi devices from various manufacturers of electrical equipment, meters and smart energy enables products to allow manufactured. In this project gives the intelligent operation for lamps and fans. Here the system is connected with temperature control and lamp control. Light dependent resistor (LDR) and Temperature sensor (LM35) are the main components for this automatic control of lamps and fans. Here the LDR is responsible for lamp control and LM35 is responsible for controlling the operation of fan.

I. INTRODUCTION

The Intelligent management of the power system facilitates the joint use the current and minimizes power loss during transmission and power consumption is highlighted by the global community, academic institutions, and state administration. The idea of a smart grid enabling technologies used in recent years for the gain of full utility, customer protection, attracting a great deal of attention in the energy industry and academia. In continued growth of popularity and functionality by mobile devices, demand advanced mobile applications widespread in human life.

The use of Web Services is an open and interoperable method for providing remote access service or applications can communicate with each other [1], [2].

An attractive market for home automation and network of busy families and individuals will have physical limitations. ARDUINO and Wi-fi shield, and it was the smart home micro web server. Arduino is an open source electronics proto typing platform on the basis of flexible, easy to use hardware and software. The Arduino I board have the microcontroller with

54 digital input / output pins [3]. The Wi-fi interface in Arduino through the serial peripheral interface (SPI) pins. The low-voltage switching relays were used to integrate devices with Arduino will show the switching functionality. The LM35 temperature sensor is used to control a smart home environment.

II. RELATED WORKS

A. general smart home design

Smart Home is applied in order to provide comfort, energy efficiency and better security. Smart Home System is still rarely used in Indonesia because of the cost and the difficulty of getting the device. The objective of this paper is to offer a Small Smart Home System designed and created by utilizing WLAN network based on Arduino microcontroller. The system is able to monitor and control lights, room temperature, alarms and other household appliances. Results from testing the system show proper control and control monitoring functions can be performed from a device connected to a network that supports HTML [4].

III. EXISTING SYSTEM

An isolated WSN with one coordinator, which is integrated into the PLC transceiver, is established in each room. The existing system of home automation system is shown in Figure 1. The coordinator is responsible for transferring environmental parameters obtained by WSNs to the management station via PLCs.

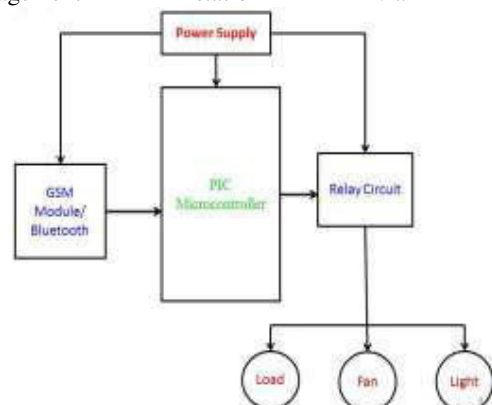

IV .PROPOSED SYSTEM

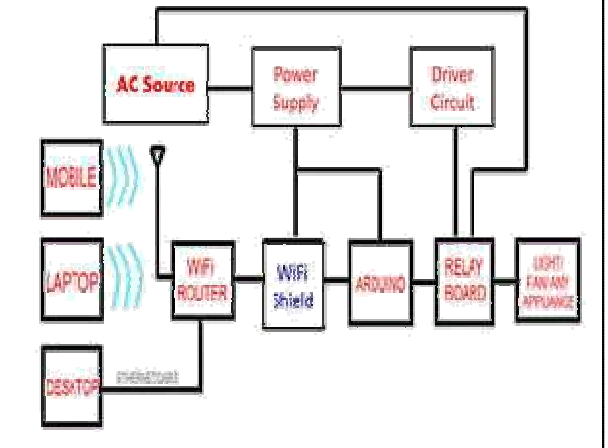
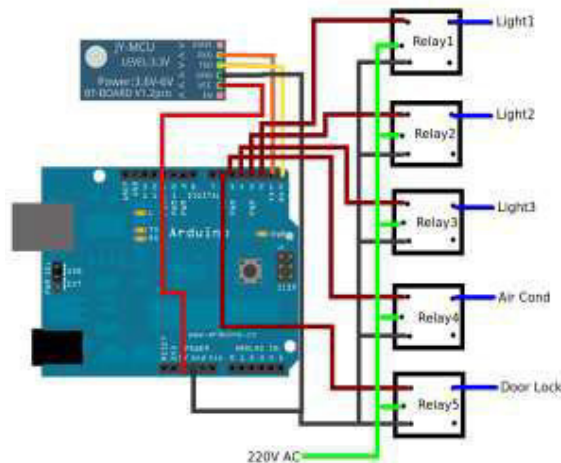

. We'll use a simple Web server application running on Arduino that communicates via HTTP

The proposed system hardware and software are implemented in this work. The expected work contributes towards the development of ubiquitous home networks. The part of future work applied in IEEE 802.15.4 standard technology in our home.

V.HOME AUTOMATION SYSTEM

Central controller (Arduino) receiving commands used to perform. You may connect to the Internet through a Wi-fi shield mounted on the Arduino. On the user side, provides a portable interface to the system as a whole through an easy-to-use application.

- Can either be wired mobile device of the central control unit (through the USB cable, for example), or connection with this wirelessly. Within the home, wireless connectivity can be achieved by using the Wi-fi shield on the central console.
- This way, you will be able to access the console, either locally or remotely through the Internet.

In this case, client/server architecture is the one to choose, because the central console as a static entity that responds to requests from Whole process smart home automation shows the whole process Smart home automation system. Hence need for server (at the application level, any piece of code that can respond to client requests) is closely linked to the company

VI. INPUT /OUTPUT BLOCK

Input/output block consists of two pieces of PIR (Passive Infra-Red) motion sensor and an LM35 temperature sensor as inputs and some lamps, sockets, relay and buzzer as outputs. PIR sensor is used to detect the presence of motion. The sensor readings are used to turn off the lights if there is no activity and turn on the lights otherwise. In addition, this sensor is also used for security systems to detect suspicious movements. If it detects any suspicious movement an alarm (buzzer) will sound. An LM35 is functioning as temperature monitoring. This sensor also serves as an input in order to execute some sockets. The socket will in on condition when the temperature exceeds a certain limit. This condition will activate a fan or Air Condition (AC) while connected to the socket. Connection circuit between microcontroller system with a PIR sensor and an LM35 sensor is Shown in Figure 5 and Figure 6. Output part consists of the relays and buzzer. Buzzer serves as a warning alarm when there is suspicious movement. Relays connected with lamps and socket [8].

A. Automatic Lamp control

Figure 5: Connection Circuit with PIR Sensor In this project gives the intelligent operation for lamps and fans. Here the system is connected with temperature control and lamp control. Light dependent resistor (LDR) and Temperature sensor (LM35) are the main components for this automatic control of lamps and fans. In Figure 5 show

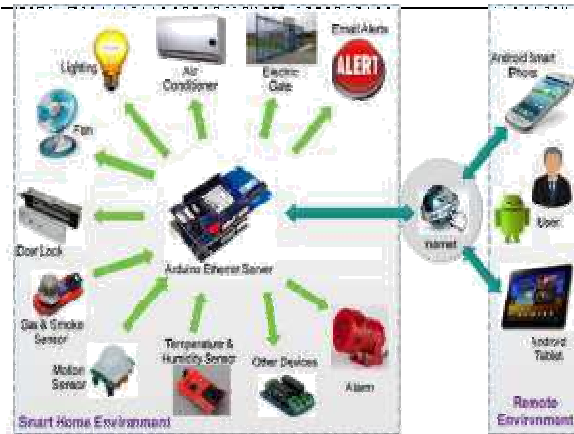

Connection circuit of arduino with PIR Sensor for lamp control. Here the LDR is responsible for lamp control and LM35 is responsible for controlling the operation of fan. In lamp control, LDR values are previously set. Then the darkness falling on the LDR due the sunset. The microcontroller receives the resistance value from LDR. When the controller attains the limit, the lamp will glow.

B. Automatic Fan and AC control

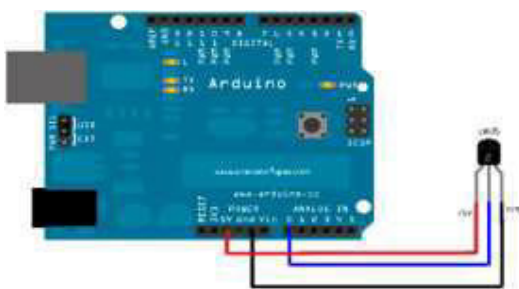

Automatic fan and control circuit connection is shown in Figure 6. In fan/AC control, the temperature values are previously set. During daytime, the temperature values are about 35oC. Then the microcontroller will receive the signal from LM35, and turns ON the port, which is connected to AC/fan. During winter season temperature reduced as below 20oC. Then there is no need of fan/AC. Hence the fan/AC will turn off.

5. MAIN COMPONENTS

A. ARDUINO CONTROLLER.

In Figure 7 shows the diagram of Arduino controller. Arduino is a unique Arduino board which features a WIZ net Wi-fi port, a Wi-fi socket, nRF24L01+ module interface and an ATmega328.

This board will add wireless ESP8266 wi-fi shield control as well as internet connectivity to the project [10].

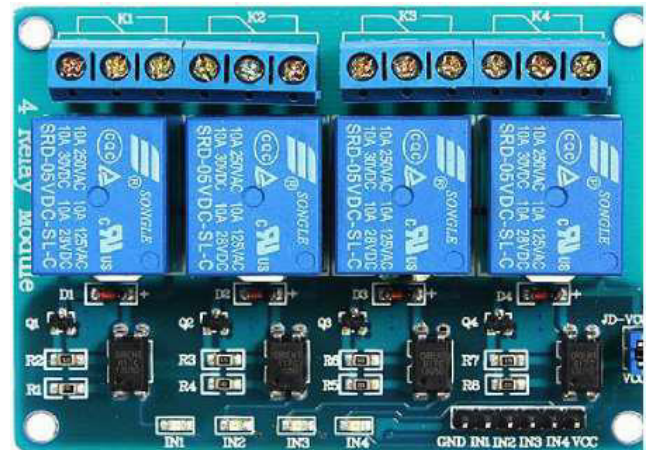

B. WI-FI SHIELD

Wi-Fi is an open global standard built on the IEEE 802.15.4 MAC/PHY. Wi-fi defines a network layer above the 802.15.4 layers to support advanced mesh routing capabilities.

The Wi-fi specification is developed by a growing consortium of companies that make up the Wi-fi Alliance. The Alliance is made up of over 300 members, including semiconductor, module, stack, and software developers in Figure 12. [11]. Wi-fi Series 2 The difference between Series 1 (S1) and Series 2 (S2) is that the latter enhances the power output of the antenna to 2mW [11].

S2 also enhances the data protocol of the Wi-fi module. S2 is similar to S1 in enabling simple and easy communication between microcontrollers and supporting point-to-point and point-to-multi point communication [12]. The connection diagram of esp8266 is shown in Figure 8. **Figure 8:** ESP 8266 node mcu Wi-fi shield

C. POWERSUPPLY

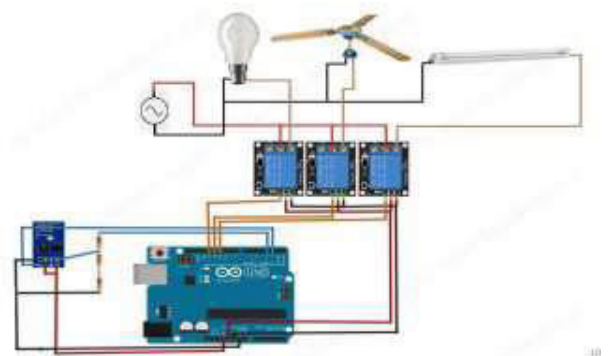
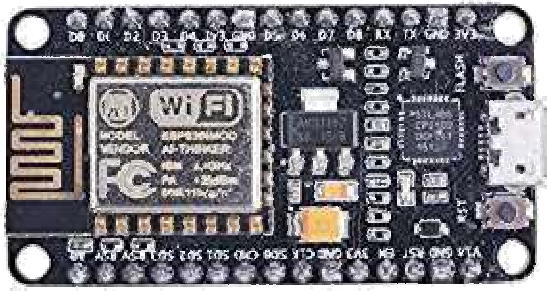

Figure 9: Power circuit



D. RELAY CIRCUIT

First part is the smart switch apparatus that is connected to the existing wiring of the electrical appliances in the house, such as a ceiling air condition and lamp in order to get power supply. This unit will receive supplies from the lives and neutral of home supply that are connected to the power module. It is 240 VAC to convert (AC) to (DC) with 5V rectifier type DC power supply Wi-fi adapter. The relay circuit is shown in Figure 10. the function of the relay module as normal switch "ON" and "OFF" will turn a lamp. An infrared detection system consists of infrared sensor as an input, while the relay module as starting Arduino Wi-fi adapter. The Wi-fi is a feature-rich RF module for use on a wireless sensor network. The IEEE 802.15.4 protocol greatly reduces the work of the programming ensuring data communications. The Wi-fi has many other features for use in a WSN beyond its networking ability [13].

Figure 11: System overview

Figure 11 shows the system overview of the home automation system. It which includes almost everything you need. However, since Arduino version 0018, because of the implementation of SPI and because the Arduino Wifi Shield communicates with the Arduino board through SPI, we have to include something more. The data in the database to transfer on the same web page hosting server to show the data that is the switching state. The web page on hosting server can read and update data in database. Writing the Code for the Web Client For the Webenabled light switch, we will create a simple Ruby on Rails project to manage the user interface interaction first via a web browser. We won't spend a lot of time on the user interface, though; since that will ultimately be the job of the custom Android application we will create after the web interface is functionally tested.

The Android app was designed to show the switch is the same as the web page on hosting server. It can also read update data on the database by touching the "ON" or "OFF" and appears on the button as on the website. This smart switch device, the lamp in a house controlled manually with the infrared switches detection system or wirelessly with Android App [14].

The android platform app



Fig.12 Screen shots of the proposed smart home app The Figure 12 shows Screen shots of the proposed smart home. There are several platforms for developing smart phone applications such as Windows Mobile, Symbian, iOS and Android. In the proposed system, the Android platform app is developed as most of the phones and handy devices support Android OS. Java programming language using the Android Software Development Kit (SDK) has been used for the development and implementation of the smart home app [15]-[17].

- Remote connection (via internet) to the smart home micro web-server; require server real
- IP and user authentication.
- Device control and monitoring.
- Scheduling tasks and setting automatic control of the smart home environment.
- Password change option.
- Supports voice activation for switching functions

CONCLUSION

In this paper presents the new circuit topology for monitoring and control the home electrical devices by using the flexible home-based Android smart phone at a reasonable price and implemented by wireless transceiver and IBOARD. The Arduino as well as using android app for system control configuration. The proposed new circuit topology is used in a quiet based web services in an interoperable application layer for communication between the remote user and the home device. All Android-based smart phone, the Wi-Fi connection is the support built; the home access device to control can use the phone, Wi-Fi, 3G or 4G to access the Web page on hosting server using Android App.

REFERENCES

- Andi Adriansyah, Akhmad Wahyu Dani" Design of Small Smart Home Control Systems Based on Wireless Sensor Networks and Power Line Communications" 10.1109/TIE .2014 .2379586, IEEE Transactions on Industrial Electronics. Kim Baraka, Marc Ghobril, Sami Malek, Rouwaida Kanj, yman Kayssi"Low cost Arduino/Android-based Energy-Efficient Home

Automation System with Smart Task Scheduling" 2013 Fifth International Conference on Computational Intelligence, Communication Systems and Networks. Zhenyu Zoua, Ke-Jun Lib*, Ruzhen Lia and Shaofeng Wub " Smart Home System Based on IPV6 and ZIGBEE Technology" Procedia Engineering 15 (2011) 1529 – 1533

Rajeev Piyare "Internet of Things: Ubiquitous Home Control and Monitoring System using Android based Smart Phone" International Journal of Internet of Things 2013, 2(1): 5-11 Yue Li " Design of A Key Establishment Protocol for Smart Home Energy Management System" 2013Fifth International Conference on Computational Intelligence, Communication Systems and Networks.

Shiu Kumar"UBIQUITOUS SMART HOME SYSTEM USING ANDROID APPLICATION" International Journal of Computer Networks & Communications (IJCN C) Vol.6, No.1, January 2014 Andi Adriansyah, khmad Wahyu Dani" Design of Small Smart Home System Based on Arduino" 2014 Electrical Power, Electronics, Communications, Controls and Informatics Seminar IBoard datasheet by "www. iteadstudio.com " Tech Support: support@iteadstudio.com

XBee datasheet by Digi International, Inc. All rights reserved"www.digi.com" rf-experts@digi.com

Nazrul Anuar Nayan, Ili A.M. Ikhsan, Yasuhiro Takahashi " Using ZigBee Communication Technology in a smart Home Wireless Sensor Network "Proceedings of Second International Conference on Modern Trends in Science, Engineering and Technology 2014"

Arduino Technical specs "www.arduino.cc/en/Main/arduino-board-uno"" Getting Started with XBee RF Modules" Version 1.0 by Martin Hebel and "C Programming for Arduino" Julien Bayle Copyright © 2013 Packet Publishing "Programming Your Home Automate with Arduino, Android, and Your Computer" Mike Riley, Copyright © 2012 The Pragmatic Programmers, LLC. ZigBee Communication Technology in a smart Home Wireless Sensor Network "Proceedings of Second International Conference on Modern Trends in Science, Engineering and Technology 2014"

Arduino Technical specs www.arduino.cc/en/Main/arduino-board-uno " Getting Started with XBee RF Modules" Version 1.0 by Martin Hebel and George Bricker with Daniel Harris

[15]. R.Nagarajan and M.Saravanan. "Performance Analysis of a Novel Reduced Switch Cascaded Multilevel Inverter," Journal of Power Electronics, Vol.14, No.1, pp. 48-60. 2014.

[16].R.Nagarajan and M.Saravanan "Staircase Multicarrier SPWM Technique for Nine Level Cascaded Inverter," Proceedings of the International Conference on Power, Energy and Control, IEEE Press, pp-668-675. 2013.

[17]. " C Programming for Arduino" Julien Bayle Copyright © 2013 Packet Publishing..

J.Chandramohan received his B.E. in Electrical and Electronics Engineering from Bharathiyar University Coimbatore, India, in 2003. He received his M.E. in Power Electronics and Drives from Anna University, Coimbatore, India, in 2010. He is currently working toward his Ph.D. in Power System at Anna University Chennai, India. He is currently working as a Assistant Professor of Electrical and Electronics Engineering at Gnanamani College of Technology, Namakkal, Tamilnadu, India. His current research interest includes Power System and High Voltage Engineering.

R. Nagarajan received his B.E. in Electrical and Electronics Engineering from Madurai Kamarajar University, Madurai, India, in 1997. He received his M.E. in Power Electronics and Drives from Anna University, Chennai, India, in 2008. He received his Ph.D in Electrical Engineering from Anna University, Chennai, India, in 2014. He has worked in the industry as an Electrical Engineer. He is currently working as Professor of Electrical and Electronics Engineering at Gnanamani College of Technology, Namakkal, Tamilnadu, India. His current research interest includes Power Electronics, Power System, Soft Computing Techniques and Renewable Energy Sources.

